



EB40 EasyBatch  
Single Stage Batch Controller



## General Information

---

This manual provides the necessary information for installation and operation of your FLOMEC batch controller; for detailed information on any flow meters or accessories supplied with your controller please consult the relevant flow meter product manual. This controller should only be installed and maintained by persons familiar with local regulations, particularly those for workplace Health and Safety.

For best results, please make yourself familiar with the contents of all relevant product manuals prior to installation and commissioning. If further assistance is required please consult the distributor from whom you purchased your device.



### **CAUTION**

***This electronic device is not suitable for use in a potentially explosive atmosphere, which may exist if you are measuring flammable liquids. Please refer to the manufacturer for an alternate product if your installation contains a potentially explosive atmosphere.***

### **DISPOSAL WITHIN THE EUROPEAN UNION - WEEE**



- The WEEE Directive requires that this product be recycled when disposed of within the European Union
- The crossed out wheeled bin symbol shown in this manual signifies that this product should not be disposed of in general waste or landfill.
- Please contact the local dealer or national distributor from whom this product was purchased for information on recycling electronic equipment within your region.

# Table of Contents

<b>1.</b>	<b>Introduction .....</b>	<b>5</b>
1.1	<i>Product Overview.....</i>	5
1.2	<i>Specifications.....</i>	6
<b>2.</b>	<b>Quick Start Guide.....</b>	<b>7</b>
<b>3.</b>	<b>Mechanical Installation.....</b>	<b>8</b>
3.1	<i>General Requirements.....</i>	8
3.2	<i>Electrical Entries.....</i>	8
3.3	<i>Integral Meter Mounting .....</i>	8
3.4	<i>Wall and Pipe Mounting .....</i>	8
3.5	<i>Panel Mounting.....</i>	9
<b>4.</b>	<b>Electrical Installation .....</b>	<b>9</b>
4.1	<i>Terminal Identification .....</i>	10
4.2	<i>Connecting Power .....</i>	11
4.3	<i>Connecting a Flow Meter.....</i>	12
4.4	<i>Connecting a Solenoid Valve.....</i>	14
4.5	<i>Batch Interlock .....</i>	17
4.6	<i>Remote Switches .....</i>	18
<b>5.</b>	<b>Operation .....</b>	<b>19</b>
5.1	<i>LCD Display.....</i>	19
5.2	<i>Keypad Function.....</i>	20
5.3	<i>Enter a New Batch Preset .....</i>	24
5.4	<i>Select a Common Batch Preset .....</i>	25
<b>6.</b>	<b>Configuration Settings.....</b>	<b>26</b>
6.1	<i>On-Screen Configuration Menu .....</i>	26
6.2	<i>PIN Protection .....</i>	26
6.3	<i>Engineering Units.....</i>	26
6.4	<i>Time-base for Rate.....</i>	27
6.5	<i>Count Up or Count Down .....</i>	27
6.6	<i>Decimal Places .....</i>	28
6.7	<i>Sensor Type Configuration .....</i>	28
6.8	<i>Calibration Data.....</i>	29
6.9	<i>Advanced Options Menu.....</i>	30
6.10	<i>Diagnostic Options.....</i>	32
<b>7.</b>	<b>Troubleshooting.....</b>	<b>33</b>
7.1	<i>Troubleshooting Summary.....</i>	33
7.2	<i>Troubleshooting Steps.....</i>	34
<b>8.</b>	<b>Configuration Menu Flowchart .....</b>	<b>37</b>
<b>9.</b>	<b>Spare Parts .....</b>	<b>41</b>
<b>10.</b>	<b>EU Declaration of Conformity.....</b>	<b>42</b>



*This product can be easily configured using FLOMEC CDS software for windows PC's*

*To download the software please navigate to **[flomec-cds.com](http://flomec-cds.com)***

*Here you will also find videos demonstrating the use of the software for easily configuring the FLOMEC EB40 batch controller*

# 1. Introduction

## 1.1 Product Overview

The EB40 “Easy Batch” is a single stage batch controller designed for a simple batching system. It can be mounted directly on a FLOMEC flow meter or field mounted and is compatible with a variety of common signal types. The EB40 is also USB enabled and may be configured on a windows PC using a software utility downloaded from the FLOMEC website. This instruction manual contains some basic information on using the FLOMEC software utility, and more information is available by watching the instructional videos on the FLOMEC website.

### ***Environments***

The instrument is weatherproof to IP65 standards; a UV resistant glass reinforced nylon housing with stainless steel screws and Nitrile seals allow the instrument to maintain its environmental protection across a wide operating temperature range. A powder coated aluminium enclosure is available as an option providing greater impact resistance. The instrument suits harsh indoor and outdoor environments & conforms to the European Directive for Electro Magnetic Compatibility.

### ***Features***

Display options of a batch total, accumulated total, and flow rate are available on the LCD. Flows are computed using 5-point linearisation which allows accuracy improvements for the connected flow meter. A single stage transistor output is available for solenoid control, with a mechanical relay available as an option when purchased. A batch memory is available for quick selection of your ten most common batch volumes. Automatic batch overrun can be selected to compensate for slow closing valves or lags in the system. The unit can be configured via PC with a USB connection.

### ***Installation***

Specifically engineered to be directly mounted on a variety of flow meters, wall or surface mounted, pipe or panel mounted. Various mounting kits are available. The instrument requires an external DC supply but has an internal battery to allow configuration prior to installation, and to maintain current values on the LCD in the event of power loss.

## 1.2 Specifications

<b>Physical</b>	Glass reinforced Nylon (PA6) with a Polycarbonate lens, Santoprene gasket, polyester decal. Enclosure provides an IP rating of IP65 Optional powder coated Aluminium enclosure
<b>Operating Temperature</b>	-30°C ~ +80°C (-22°F ~ +176°F)
<b>Electrical Entries</b>	3 entries - M16 x 1.5 conduit thread
<b>LCD Display:</b>	Large dual line LCD with 6 characters x 17mm high on top line 8 characters 7mm high on bottom line. Backlight available with external DC power
<b>Units</b>	Units are selectable for Litres, Cubic Metres, US Gallons, Imperial Gallons, Millilitres (Cubic Centimetres), Quarts, Fluid Ounces, Cubic Feet, Barrels, Kilograms, Pounds, or Custom Units of mass are configured by setting a units/litre conversion value in the configuration menu
<b>Flowmeter Input Signals</b>	Pulse/frequency input compatible with pulse signals from most flow meters.
<b>Compatible Flowmeter Sensors</b>	Reed Switch – 120Hz maximum NPN (hall effect sensor) – 2kHz maximum Variable Reluctance Coils (Turbine Flow meters) – 2kHz maximum Weigand Sensors (voltage pulse signals) – 2kHz maximum <b>Minimum signal amplitude for Coil signals is 15mV pk-pk</b>
<b>Sensor Power</b>	12V regulated sensor supply is available with external DC power applied.
<b>Safety Interlock Input</b>	Normally open (NO) dry contact, switch, or reed switch input
<b>External Switch Inputs</b>	Momentary normally open (NO) switch input Four inputs for remote access to all operator keys
<b>Battery Power</b>	AA (14505) 3.6V Lithium Thionyl Chloride Battery Expected battery life is 10 years as a back-up battery
<b>External DC Power</b>	Regulated 12V ~ 30V DC Typical current draw on external power is 100mA across this voltage range
<b>Digital Output</b>	NPN (open collector, sinking) output, 30Vdc / 1A maximum
<b>Relay Output (Optional)</b>	Optional mechanical relay for high current DC loads: 30Vdc / 5A maximum External equipment is required for AC loads (wiring diagram 4.4.4)

## 2. Quick Start Guide

### ***Mounted on a FLOMEC Flow Meter***

If your EB40 is factory mounted to a FLOMEC flow meter, many of the necessary parameters will be factory configured. To make the unit operational please refer to the mechanical installation requirements in the flow meter instruction manual and then make electrical connections a solenoid valve as per **section 4** of this manual.

Note that the EB40 will be factory set to either litres per minute or gallons per minute depending on the model purchased. If there is a need to change the units of measure this can be done through the on-screen configuration menus or using the USB connection and the FLOMEC CDS software. Default settings will be configured, for example overrun correction will be turned on. If changes to the configuration are required to suit user preferences, please refer to **section 6** of this manual.

### ***EB40 Purchased Separately***

If your EB40 is purchased as a separate unit, and not factory fitted to a FLOMEC flow meter there will be some additional steps before it can operational. Please perform the Mechanical and Electrical installation as per **Sections 3 & 4**. Please note that separately purchased batch controllers may be mounted direct to an existing FLOMEC flow meter if purchased as a 'meter mount' model, or by purchasing a separate Meter Mount Rear Housing Kit.

The user must then configure the controller using the on-screen menus or the windows PC utility. The user should set the signal type, flow meter calibration data, and adjust any default values for units of measure or advanced settings to suit user preferences.

### ***Third Party Flow Meter Installation***

If the EB40 is being installed with a third-party flow meter, mounting directly to the flow meter may not be possible, and a remote mount installation will be required. Please refer to **Section 3** for the physical installation. Refer to the instruction manual for the flow meter to determine sensor type and wiring connections and then refer to **section 4** to determine electrical connections.

The user must then configure the controller using the on-screen menus or the FLOMEC CDS software. The user should set the signal type, flow meter calibration data, and adjust any default values for units of measure or advanced settings to suit user preferences. All sensor/signal information and calibration data should be available in the documentation supplied with the third-party flow meter, in case of any missing information please contact the manufacturer of the third-party flow meter.

## 3. Mechanical Installation

### 3.1 General Requirements

Installation of this product should only be carried out by suitably qualified/trained personnel with an understanding of local regulations regarding electrical installations.

It is recommended that the controller is installed in a location where it is shielded from extreme varying weather conditions, and from chances of physical impact. Never install the instrument in an area which will expose it to temperatures outside its specified operating temperature range.

### 3.2 Electrical Entries

Each instrument is equipped with three electrical entries which are factory sealed to maintain the IP rating of the enclosure. To gain access to an electrical entry remove the threaded plug.

***Always use IP rated cable glands when fitting cable to the instrument.*** Any unused electrical entries must be sealed using an M16 threaded conduit plug with an appropriate IP rating (IP66 or IP67 is recommended)

### 3.3 Integral Meter Mounting

This instrument may be purchased as a meter mount display which will mount onto any OM Series flow meter. For any instruments purchased as field mount, these may be converted to a meter mount instrument by purchasing a Meter Mount Kit (*see section 9*)

For mounting this instrument on an OM Series flowmeter with a process temperature of over 80°C/176°F there is a Cooling Fin Kit (***part no. 1502015***) which allows this; these may be retro-fitted in the field with minimal effort.

### 3.4 Wall and Pipe Mounting

Mounting of the instrument on a pipe or flat surface (such as a wall) can be accomplished using the Wall Mount Kit (***part no. 1522001***) or Pipe Mount Kit (***part no. 1522002***).

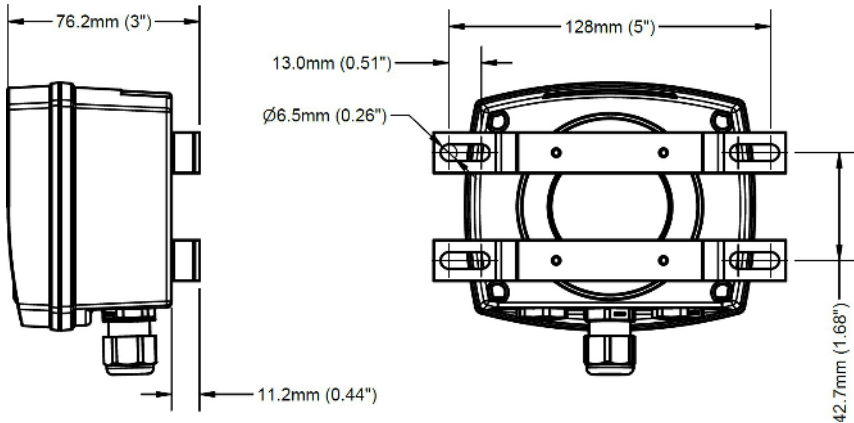

### 3.5 Panel Mounting

Mounting of the instrument in a panel requires a 95mm x 76mm (3.75" x 3.0") rectangular hole to be cut in the panel – for panels thicker than 3.2mm (1/8") longer screws should be used. The enclosure gasket must be used to maintain weather protection when panel mounted. It is possible to maintain the IP65 rating for the outside of the panel with an accurately cut hole and a flat/smooth panel.

The rear enclosure of the instrument should be mounted behind the panel to protect the electronics module from damage and provide separation from any conductive components inside the panel/cabinet. **However, it should be noted that once panel mounted the rear of the enclosure is no longer protected from water ingress.**

## 4. Electrical Installation

All flow meter wiring connections should be made with good quality shielded instrument cable; wiring between terminals which are inside the instrument enclosure, or wiring to a flow meter and an integrally mounted controller may use non-shielded wire. Solenoid valve wiring can use non-shielded wire. Cable shields or drain wires should be connected to the instrument ground (GND) at the instrument end only – isolate the shield/drain wire at the flow meter end of the cable.

Solenoid valve wiring should be kept physically isolated from any signal cables coming from the flow meter. Signal and control wiring should not be run in common conduit, and signal wires should be kept well clear of any solenoid coils or pump motors.

The terminal connections on the controller will allow for wiring up to 1.5mm<sup>2</sup> cross section (16AWG). Wire insulation should be stripped to a length of 7mm (1/4”) and conductors should be fitted to the terminals so that there is minimal exposed conductor. Terminals can be tightened with a 2.5mm (0.1”) flat blade screw driver.

### 4.1 Terminal Identification

The terminal connections are divided into 4 separate sections by their function, see image below. There is a separate ground (GND) terminal in each section of terminals; as this instrument has a common ground, all GND terminals are internally connected.

Terminal connections for the optional mechanical relay model is shown on the next page.

#### Standard Model

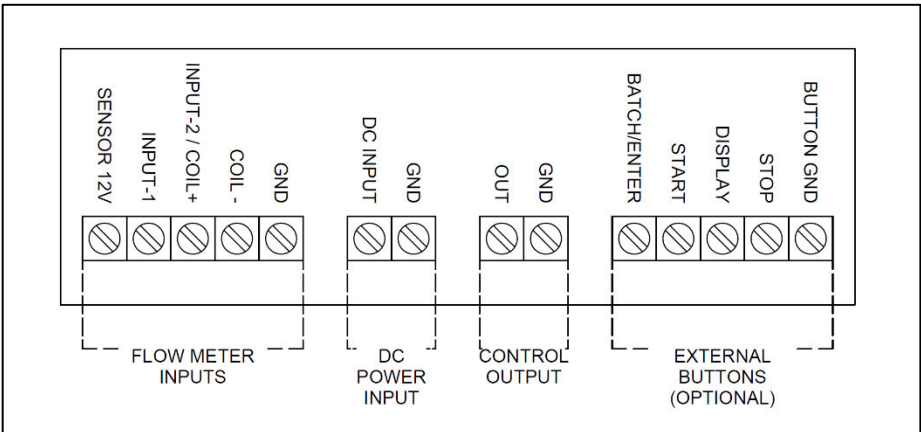

#### Optional Mechanical Relay Model

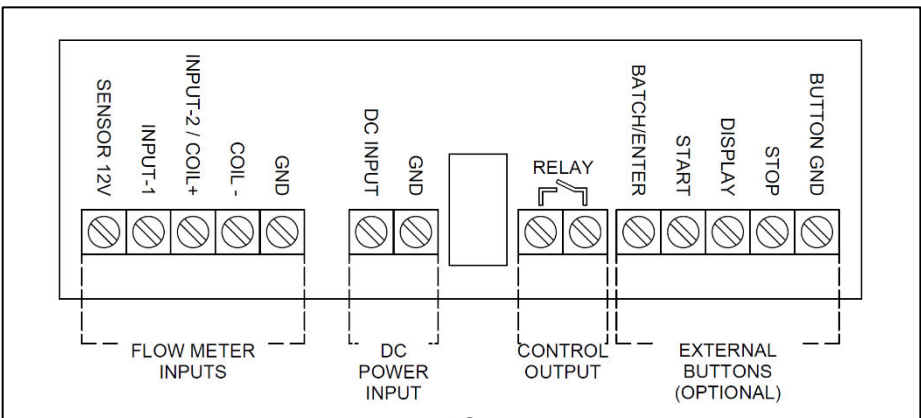

## 4.2 Connecting Power

### 4.2.1 External DC Power

External DC power is required in the range of 12-30V DC; this will provide the necessary power to operate the controller, switch the solenoid valve or mechanical relay, power the LCD backlight, and provide power for the sensor supply terminal.

Before DC power is connected to the batch controller the LCD will be active, and the user will be able to enter configuration menus and setup their controller. The battery is only able power the device for setup and does not provide enough power for operation.

### 4.2.2 Sensor Supply

The instrument is equipped with a 12V regulated sensor supply terminal which is suitable for powering hall-effect sensors in FLOMEC flow meters. The sensor supply is only available when the instrument is connected to an external 12-30V DC supply, so while the controller is operating on backup battery any flow meter sensors will not receive power.

### 4.2.3 Battery Power

The EB40 is fitted with a Lithium Thionyl Chloride battery which allows the user to configure the batch controller prior to electrical installation and will prevent loss of current values or batch progress in case of a power failure.

Once DC power is connected to the controller, the battery will go into standby as a backup power source. The battery is expected to have a lifetime of 8-10 years while in standby

For battery replacement one of the below options is recommended, however any 3.6V Lithium Thionyl Chloride battery will be acceptable. Alkaline batteries or 3V lithium batteries are not suitable.

<b>Manufacturer</b>	<b>Model</b>
Tekcell	SB-AA11
SAFT	LS14500
Tadiran	SL360S

***Use of a battery which is not a 3.6V Lithium Thionyl Chloride type will void the instrument warranty.***

## 4.3 Connecting a Flow Meter

The input type must be set in the software before the below wiring connections will function.

### 4.3.1 NPN Sensor Input (Hall Effect) - OM Series and DP Series Flow Meters

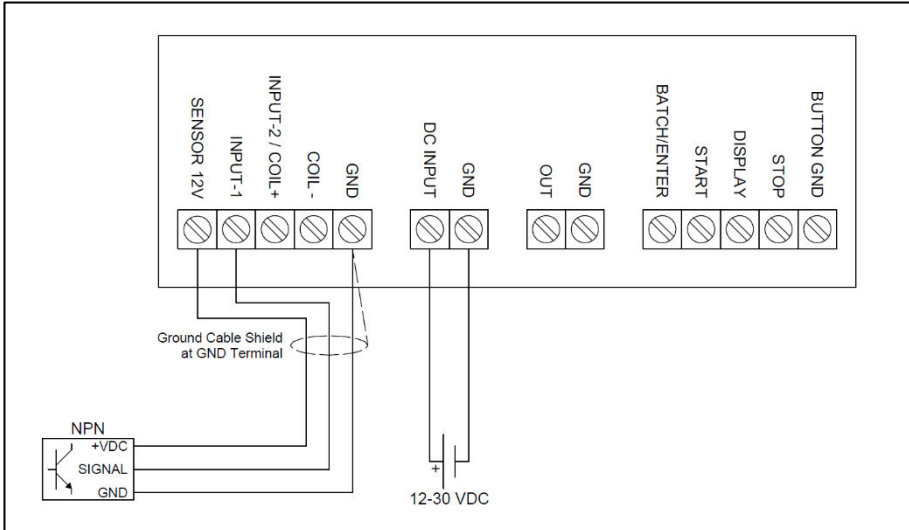

### 4.3.2 Reed Switch Input

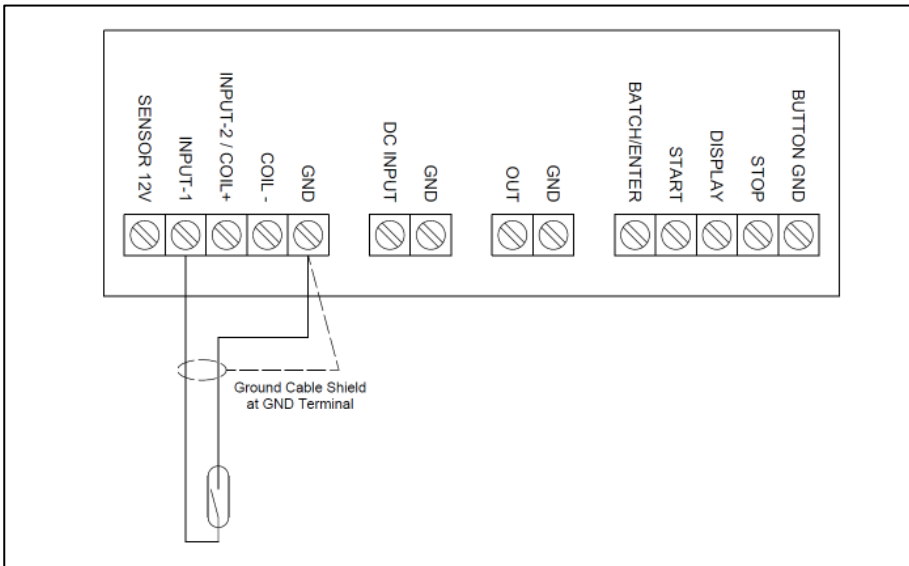

### 4.3.3 Variable Reluctance Coil Input - Turbine Flow Meters

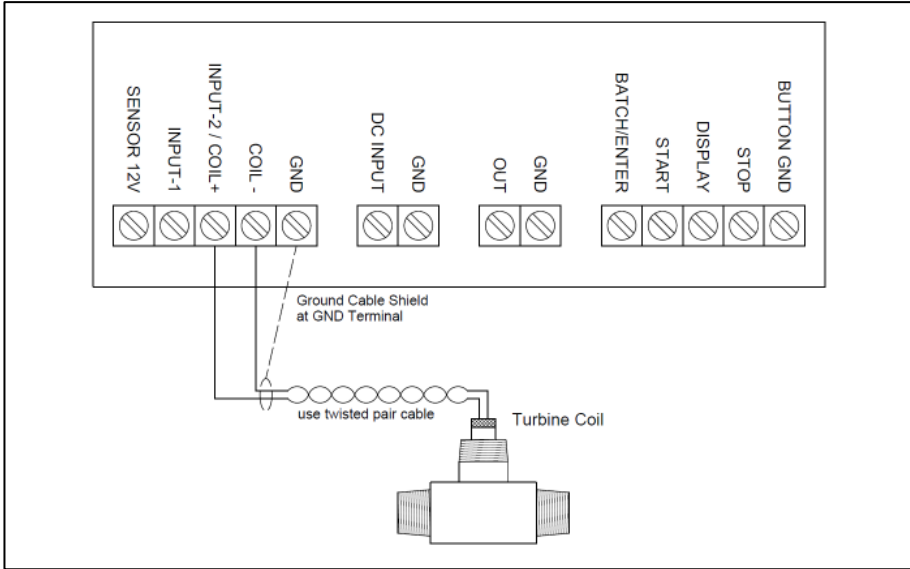

### 4.3.4 QS200 / QS100 – 2 Wire Pulse

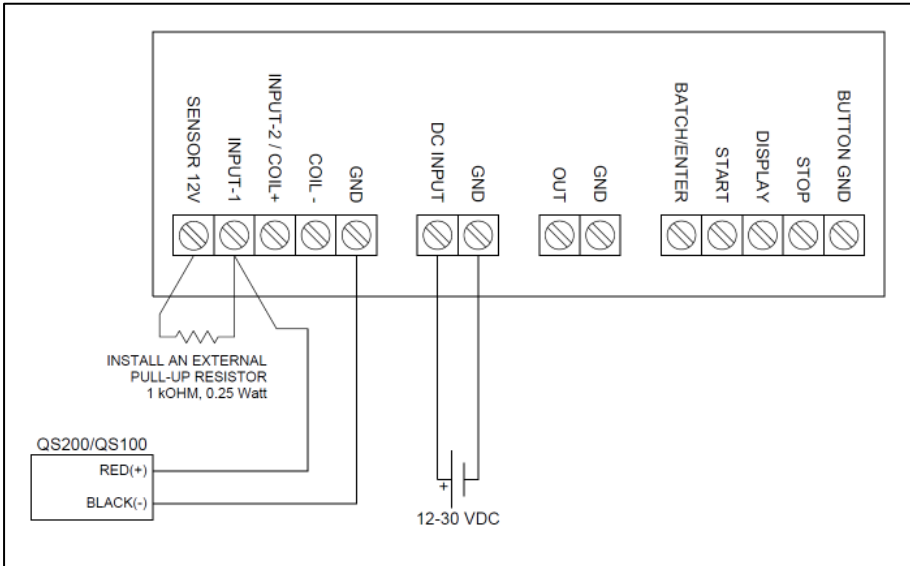

## 4.4 Connecting a Solenoid Valve

To ensure the correct model of batch controller is used with the correct wiring method for your solenoid valve or pump, please refer to the below table and the referenced wiring diagram on the following pages.

Valve or Pump Voltage	Maximum Power Rating	Controller Required	Wiring Diagram
12Vdc	12 Watt	Standard Model	4.4.1
12Vdc	60 Watt	Relay Model	4.4.2
24Vdc	24 Watt	Standard Model	4.4.1
24Vdc	120 Watt	Relay Model	4.4.2
30Vdc	30 Watt	Standard Model	4.4.1
30Vdc	150 Watt	Relay Model	4.4.2
3-wire valve	N/A	Relay Model	4.4.3
Higher Power DC Device	Refer ratings of external relay	Standard Model with additional external relay	4.4.4
115Vac / 230Vac			

### 4.4.1 DC Solenoid Valves up to 1A

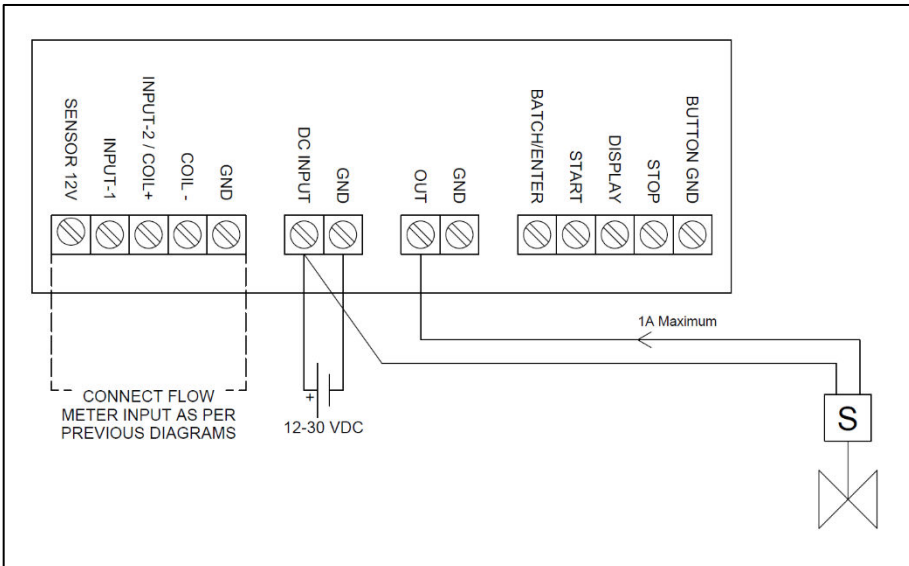

#### 4.4.2 DC Solenoid Valves up to 5A

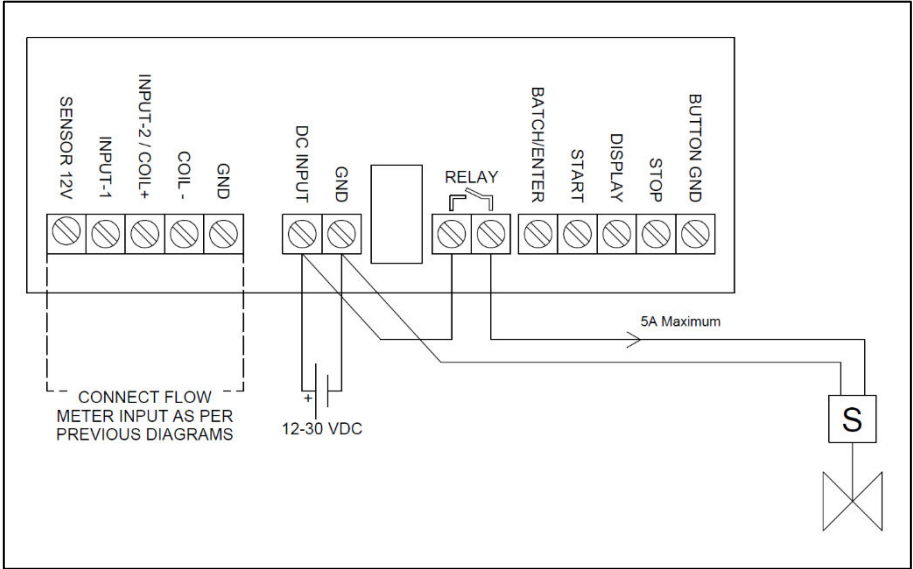

#### 4.4.3 3-wire Solenoid Valves

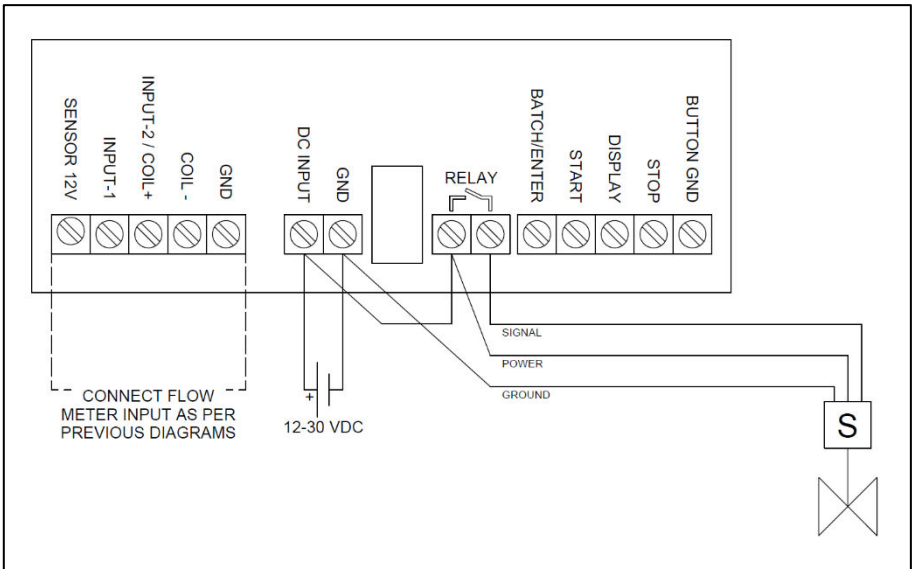

4.4.4 External Relay for High Current DC or 115Vac / 230Vac

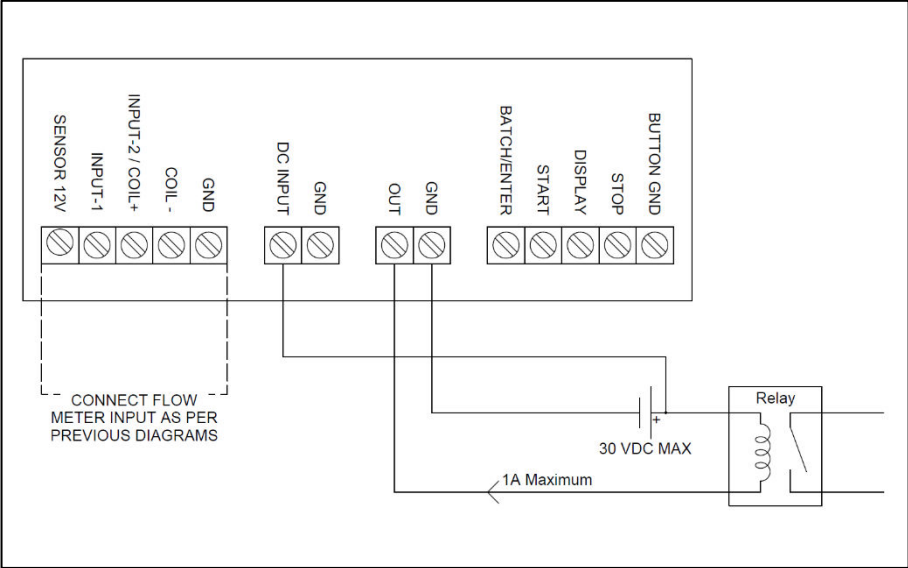

## 4.5 Batch Interlock

The EB40 can be installed using the optional Batch Interlock feature which allows the use of a limit switch or a proximity sensor to detect the presence of an un-safe condition, or to prevent starting the batch controller when a receiving vessel is not present at the dispensing point.

The Batch Interlock should be connected to a proximity sensor with a normally open (NO) dry-contact output, or a reed switch, and can be wired as below.

Please note that the **Batch Interlock input cannot be used with a Coil Input** from a turbine flow meter, due to shared input circuitry and connection terminals. For any installations using a turbine flow meter which need to use the batch interlock function, the turbine flow meter should be equipped with an amplified output (3-wire output).

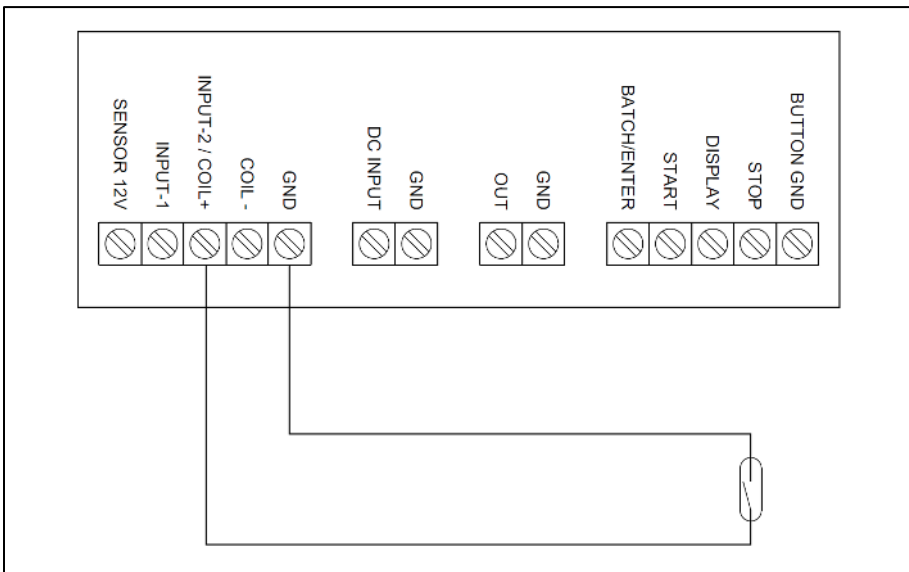

## 4.6 Remote Switches

External switches may be connected to the EB40 display to allow remote access to button functions, or to allow use of heavy industrial push buttons in environments where the standard switches may break or wear. Momentary normally open (NO) switches **MUST** always be used.

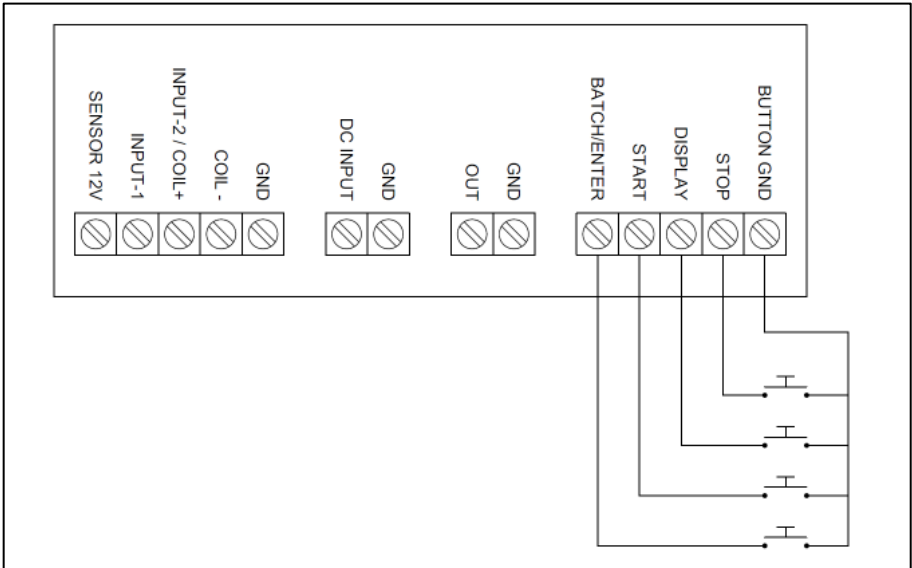

## 5. Operation

### 5.1 LCD Display



Upon entering the programming mode the LCD will conduct a display test where all LCD segments are displayed for 3 seconds



The batch value is shown on the top line of the LCD.

The bottom line of the display can show accumulated total, flow rate, or preset quantity.

When the batch is running the arrow next to the bottom LCD line will illuminate







The instantaneous flow rate can be shown on the bottom line of the display by pushing the **Display** key.

All displayed variables are individually selectable for up to 3 decimal places.

The LCD backlight will automatically illuminate once external DC power is connected to the EB40. This feature can be overridden through the configuration menu to force the backlight to 'OFF'.

## 5.2 Keypad Function

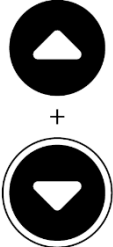
KEY	FUNCTION IN OPERATING MODE	FUNCTION IN MENUS
	<p>A single press to display batch value, second press to change batch value, hold for 3 seconds to display firmware revision number and serial number below</p>	<p><b>Enter key;</b> selects a program setting, or accepts an entered value</p>
<p><b>Start</b></p> 	<p>Press once to start the batch or resume a paused batch.</p>	<p><b>Up key;</b> moves upwards in an on-screen menu, or increments the selected digit when configuring a setting or entering a preset quantity.</p>
<p><b>Display</b></p> 	<p>Toggles the bottom display line between preset quantity, flow rate, or accumulated total</p>	<p><b>Right key;</b> moves digit selection to the right when configuring a setting or entering a preset quantity</p>
 <p><b>Stop</b></p>	<p>If a batch is running, press once to pause the batch.</p> <p>If controller is paused or stopped, press once to reset and be ready to start a new batch</p>	<p><b>Down key;</b> moves downwards in an on-screen menu, or decrements the selected digit when configuring a setting or entering a preset quantity</p>
	<p>Press and hold both buttons simultaneously for a duration of 5 seconds to enter the on-screen configuration menu</p>	<p>No Function</p>

## Operating Features

### 5.2.1 Batch Total

The running total of the current batch is displayed on the top line of the LCD. Depending on the configuration of the batch controller this value could be counting **up** from zero, or it could be counting **down** from the batch preset value to zero.

The default units for the batch total are Litres, however this can be changed by the user to any of the available engineering units (*see 1.2 Specifications*). When the display units are changed by the user the EB40 will automatically adjust the settings so that no further input is required by the user (k-factors do not need to be changed). If the EB40 is displaying a Total in Litres this will be automatically converted to the new units of measure so that no data is lost.

However, if the new unit selection results in a value which cannot be displayed it will be set to zero. For example, if display units are changed from Litres to Millilitres and the total has a value of 1000L this will be zeroed, as there is not enough display digits for a value of 1,000,000mL.

To reset the batch total the user must first stop the current process using the **Stop** key. A second press of the **Stop** key will then reset the batch total to zero. If the controller is in count down mode then it will reset to the batch preset amount.

### 5.2.2 Accumulated Total

The accumulated total is displayed on the bottom display line, the user can toggle between the accumulated total, flow rate, or batch preset by pressing the **Display** key. The accumulated total is always displayed in the same engineering units as the batch total.

The accumulated total display can only be reset to zero by accessing the on-screen configuration menu or by using the USB connection and the FLOMEC CDS software. To prevent resetting of the accumulated total the user can use the PIN Protection setting, which is accessed in the same way.

### 5.2.3 Instantaneous Flow Rate Display

The instantaneous flow rate display is displayed on the bottom display line, the user can toggle between the accumulated total, flow rate, or batch preset by pressing the **Display** key.

The flow rate display will update at a frequency of 8 times per second, however this is affected by the configured value for the 'Rate Calculation Pulses' parameter. If the update frequency of

the flow rate is too slow, consider reducing the number of pulses for the rate calculation. If it is required to stabilise an erratic flow rate display from a pulsating pump, increase the 'Rate Calculation Pulses' parameter.

Other parameters which influence the calculated flow rate value are the 'Filter' setting, and the 'Low Frequency Cut-Off' setting. Increasing the 'Filter' value will smooth out rapid changes in the flow rate to maintain a steady display. In systems where fast changes in the flow rate must be displayed to the user the 'Filter' parameter should be minimised.

The default input frequency minimum is 1Hz, with input frequencies below the Low Frequency Cut-Off the EB40 will not be able to display a flow rate – this does not affect computing volume totals. This parameter can be reduced to a minimum of 0.1Hz which will allow flow rate displays at lower flow rates while also reducing responsiveness to sudden stoppages in flow.

#### 5.2.4 Batch Preset Display

The batch preset is visible on the bottom display line, it can be selected by pressing the **Display** key. If the EB40 is in count up mode, the batch total will display zero at the beginning of a batch. If it is in count down mode the batch total will match the batch preset.

#### 5.2.5 Common Batch Presets

The EB40 contains a memory table which records ten common batch preset values, this provides a quick method for the operator to switch between batch presets without re-keying the values each time. Up to ten commonly used values are automatically stored, and the user has the option of manual sorting, or automatic sorting according to how often they are used.

Common batch presets values can be viewed by pressing the **Batch/Enter** key on the EB40 to enter the Batch Set Menu. Once the user is in the Batch Set Menu they can view all preset values by pressing the **Down Arrow** key. Common batch presets can also be viewed, edited, and sorted using the USB connection and FLOMEC CDS software.

#### 5.2.6 Maximum Batch Size Limit

The Maximum Batch Size setting is an optional safety feature that can be used to safeguard against overflowing of tanks or vessels. This ensures that an operator cannot incorrectly enter a batch preset quantity which is larger than the tank or vessel that is being used. This feature has a setting of zero by default, which turns the feature off. To turn this feature on, enter the safe fill level of your tank or vessel.

### 5.2.7 Automatic Over-run Compensation

The EB40 has an Automatic Over-run Compensation feature which will measure the amount of over-run on previous batch volumes and automatically adjust the close timing of the valve on subsequent batch volumes. Because of this feature the batch controller can be expected to have accurate batch volumes from the second batch onwards.

Automatic Over-run Compensation will remember the compensation amount even after changing to a new batch preset value. So long as no physical changes are made to the system, the user should experience an accurate and consistent process. This feature can be turned off if it is not desired. If the user wishes to reset the compensation amount for any reason they may turn off compensation and turn it back on to reset it.

With batch processes that are subject to erratic or inconsistent conditions it is possible that the Automatic Over-run Compensation feature will over-correct and exacerbate an already erratic process. In this case it is advisable to disable this feature.

### 5.2.8 Batch Interlock

The Batch Interlock function is an optional safety feature that allows the controller to prevent the starting of a batch while an un-safe condition exists. For example, if a safety door or barrier is left open, or a vessel has not been placed at a dispensing point. This feature is turned off by default and can be turned on if required.

If the interlock feature is activated in the configuration menu the batch controller will not start unless a switch circuit is closed. When choosing the switch or sensor for your interlock it is important to select a device that produces a closed circuit when a SAFE condition exists. For example, a normally open proximity switch will close the interlock circuit when a safety barrier is closed or when a vessel is placed at the dispense point.

### 5.2.9 No Signal Detection

Another safety feature on the EB40 is the No Signal Detection function, which ensures any failure of the flow meter or input wiring does not result in an uncontrolled batch and overflowing of the tank or receiving vessel.

If the batch controller doesn't receive a signal from the flow meter within a configured time-period, the screen will display an error to the user and the valve will close, stopping the batch. This feature is set to ten seconds by default, and can be configured to suit the user's requirements. For flow meters with very low resolution – for example; some water meters – it will be necessary to increase the time period for No Signal Detection to avoid false alarms.

### 5.3 Enter a New Batch Preset

To enter a new batch preset, you first access the Batch Set Menu by pressing the **Batch/Enter** key. The first option in the menu is to enter a new batch preset. By using the arrow keys the user can enter the desired quantity and then press the **Batch/Enter** key to accept. New batch presets can also be pre-configured using the USB connection and the FLOMEC CDS software.

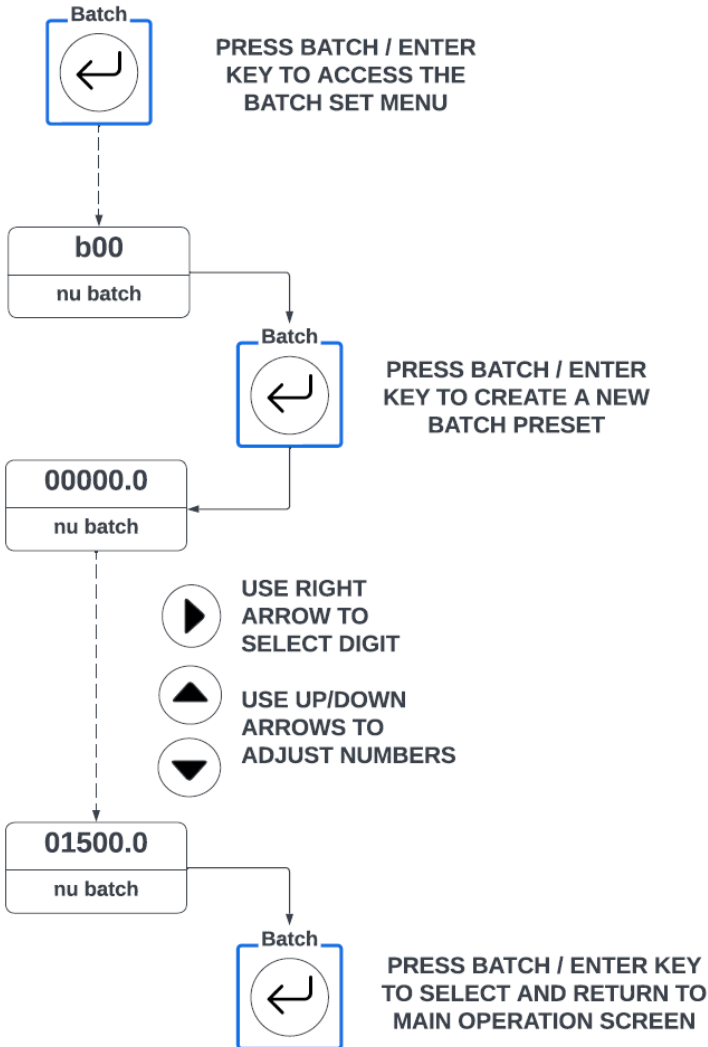

## 5.4 Select a Common Batch Preset

Previously used batch presets can be selected for repeat usage. Access the menu by pressing the **Batch/Enter** key, and select from the available volumes using the **Up Arrow / Down Arrow** keys.

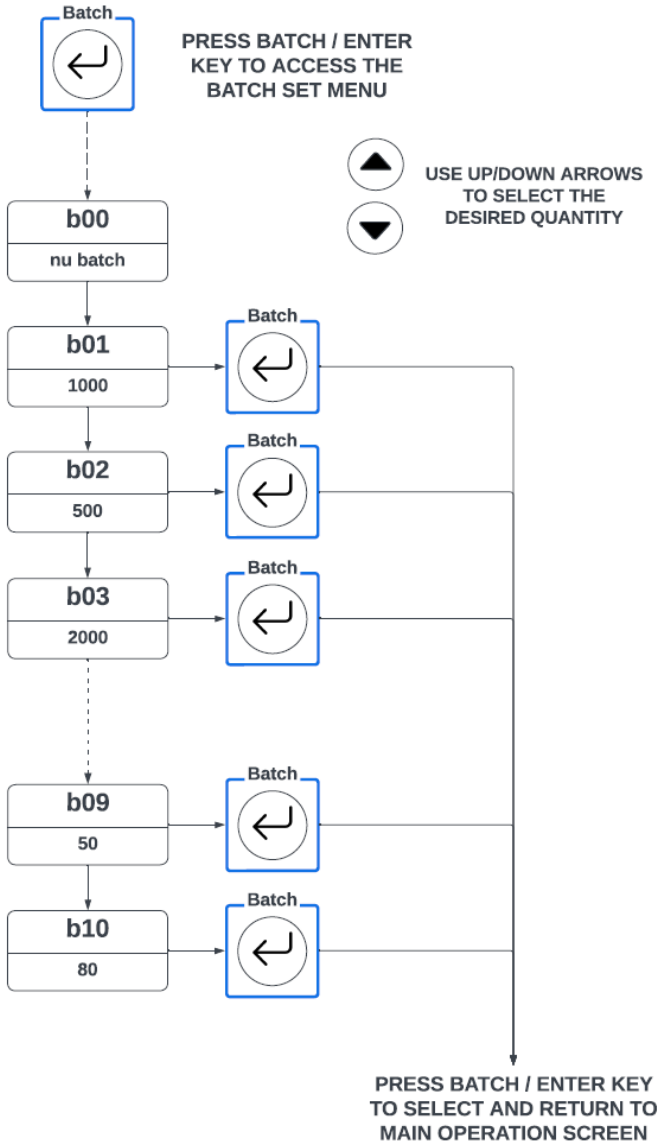

## 6. Configuration Settings

### 6.1 On-Screen Configuration Menu

The configuration of the EB40 can be altered either through the on-screen menu or accessed via the USB connection and FLOMEC CDS software.

To enter the on-screen menu the user must simultaneously hold the **Up Arrow** and **Down Arrow** keys for a period of 5 seconds. While the user is holding these buttons the LCD screen will display a countdown from 5 to 1. Once this is complete the display will energise all segments to allow inspection of the LCD and identification of any damaged display segments, before finally entering the on-screen menu. At each level of the menu the user presses the **Enter** key to allow adjustment of a setting, the **Up Arrow** and **Down arrow** keys to edit the setting, and the **Enter** key again to accept the change.

### 6.2 PIN Protection

By default, the PIN protection function is off. When a PIN is not enabled and the user enters the on-screen menu they will be asked if they want to enter a PIN. Selecting “N” will leave the PIN protection feature OFF and will progress to the next stage of the menu.

If the user selects ‘Y’ they will have enabled the PIN protection feature and may enter a PIN. Any PIN other than 0000 will engage PIN protection, or if 0000 is entered the PIN protection feature will return to OFF.

After the PIN protection mode is enabled failure to input the correct PIN will deny the user the ability to change any of the configuration settings but will allow read only access to the user so that they may view existing settings.

Only one PIN may be set at any one time, but this can be changed at any time by entering the on-screen menu, entering the existing PIN, and then changing the PIN to a new number. A second backup PIN exists in the software which can be used should the user programmed PIN be lost – contact the manufacturer should you require the backup PIN.

### 6.3 Engineering Units

The engineering units may be selected from any in the following table. The factory default units are Litres, however the user may change the display units using the on-screen menu, or the FLOMEC CDS software. Once the user has selected an alternative display unit the controller will recalculate all of the required parameters so that no further data entry is required by the user – K-factors do not need to be changed.

Display Unit	Conversion Factor (units / Litre)	Display
Litres	1	Ltr (right of screen)
US Gallons	0.264172	Ga (right of screen)
Cubic Metres	0.001	m <sup>3</sup> (right of screen)
Pounds	User prompt	lbs (right of screen)
Kilograms	User prompt	kgs (right of screen)
Imperial Gallons	0.219969	Ga (right of screen)
Millilitres (cubic centimetres)	1000	cc (main display)
Quarts	1.05669	qt (main display)
Fluid Ounces	33.814	FL.O (main display)
Cubic Feet	0.0353147	Cu.Ft (main display)
Barrels	0.0062898	bbl (main display)
Custom	User prompt	CUST (main display)

For any units that are not available in the above table the user may choose to select 'Custom' units. Once this has been selected the user will be prompted to enter a conversion factor. For example, to configure the instrument for decalitres select 'Custom' units and enter a conversion factor of 0.1 decalitres per litre.

The user may also select units of mass, either kilograms or pounds. Please note that this will always be a less accurate measurement than if you are displaying a volume unit, as we are assuming a fixed density for the measured liquid. This would only be accurate if you have a very stable temperature. Once a unit of mass is selected by the user they will be prompted to enter the number of mass units per Litre; either kilograms/litre or pounds/litre.

***For kilograms this is equivalent to the specific gravity of the liquid.***

## 6.4 Time-base for Rate

The time-base for the Rate display may be selected from any of the following; units/second, units/minute, units/hour, units/day.

## 6.5 Count Up or Count Down

The EB40 may be programmed to count down to zero from the batch preset, or up from zero to the batch preset volume.

## 6.6 Decimal Places

Decimal places are separately adjustable for Total, Accumulated Total, and Rate from zero to three decimal places.

## 6.7 Sensor Type Configuration

The sensor type can be selected from; Hall effect sensor, Reed switch, or Coil. The following table should be referenced when selecting the correct software setting for your flowmeter. It is recommended to use powered sensor options with the EB40 due to the proximity of power.

***Controllers that are factory mounted to a flowmeter will have this parameter factory set and do not require user adjustment.***

<b><i>Flowmeter Type</i></b>	<b><i>Sensor Description</i></b>	<b><i>Sensor Type</i></b>
FLOMEC Oval Gear meter	NPN hall effect sensor (3-wire)	HALL
FLOMEC G2 Turbine meter	NPN output 3-wire (conditioned signal output module)	HALL
FLOMEC DP Insertion meter	NPN hall effect sensor (3-wire)	HALL
FLOMEC Turbine meter	Turbine meters with standard 2-wire coil output	COIL
FLOMEC QS200 / QS100 ultrasonic meter	2-wire pulse signal from QS200 or QS100 water meter	HALL
Electromagnetic Flowmeter	Third Party meters with NPN pulse output	HALL
Mechanical Water Meters	Third Party water meters with reed switch output	REED

## 6.8 Calibration Data

The calibration data menu allows the user to enter up to 5 points of calibration data for their flow meter; if the EB40 was purchased integrally mounted to a flow meter then the calibration data will be factory set.

Upon entering the calibration data menu the user is able to enter up to 5 points of calibration, with each point of calibration requiring a frequency value and a K-factor. Frequency values are to be entered in Hertz (pulses/second) and can be entered with up to 4 whole numbers and 1 decimal place. K-factor values are to be entered in Pulses/Litre with up to 6 whole numbers and 4 decimal places.

***It is very important to note that K-factors are always entered in units of Litres regardless of the units chosen for the display.***

If a single point of calibration is to be entered, the frequency value is not important and any non-zero value can be entered here. After entering a non-zero value for frequency the K-factor for the flow meter may be entered. ***Please note, if there are no non-zero frequency values entered the EB40 will operate as if the K-factor has been set to 1 Pulses/Litre.***

When entering multiple points of calibration the user must calculate the frequency for each calibration point, which can be done as follows:

$$\text{Flowrate} \left( \frac{\text{Litres}}{\text{minute}} \right) \times \text{K.Factor} \left( \frac{\text{Pulses}}{\text{Litre}} \right) \div 60 = \text{Frequency(Hz)}$$

***Example: for a calibration point at 50 L/min with a K-factor of 107 Pulses/Litre the user would enter a frequency value of 89.2Hz and a K-factor of 107 Pulses/Litre***

Calibration points may be entered in any order, it is not necessary to enter them in ascending frequency order. However, if any point is entered with a frequency value of zero then all remaining calibration points will be disabled. If data is entered for the first 3 points of calibration, and point 4 is entered as zero Hz then points 4 and 5 will be disabled and the EB40 will operate with 3 points of calibration.

***For users with a QS200 or QS100 ultrasonic water meter; the calibration data to enter should be a frequency of 1Hz, and a K-factor selected from the "Reference Pulses/Litre" column of the K-factor table in the QS200 or QS100 instruction manual. Please note that the correct Pulses/Litre number must be selected based on your pipe size and your pipe schedule.***

## 6.9 Advanced Options Menu

### 6.9.1 Batch Limit

A batch limit volume may be set to prevent users entering unsafe batch volumes. This parameter may be configured up to a value of 99999.9 engineering units. If this parameter cannot be set to a large enough value for your application, it will be necessary to change the engineering units to a larger quantity – e.g. from Litres to Cubic Metres. If this parameter is set to zero the feature is turned off.

### 6.9.2 Overrun Correction

An overrun correction algorithm can be enabled to correct for batch errors from slow closing valves. This feature can be configured to ON or OFF, to reset the compensation value turn this feature OFF, and then turn it back ON.

### 6.9.3 Batch Interlock

An optional safety interlock can be enabled to ensure that a vessel is in place or a safety barrier closed before the batch controller will start a batch. This feature can be configured to ON or OFF.

### 6.9.4 No Signal Delay

If the batch controller doesn't receive a signal from the flow meter within the configured time period an error message will display and the batch will stop. The default configuration is 10 seconds, and this setting can be adjusted from zero to 99 seconds. To turn this feature OFF set to zero.

### 6.9.5 Reset Batch Table

Resetting the batch memory table can only be done at this level of the Advanced Menu. If the display is PIN protected it will not be possible to reset the batch memory table. The user will be prompted "Are You Sure" Y/N, select Y to reset and N to cancel.

Once the batch memory table is reset it is not possible to recover the values which were previously set.

### 6.9.6 Resetting Accumulated Total

Resetting the accumulated total can only be done at this level of the Advanced Menu. If the display is PIN protected it will not be possible to reset the accumulated total. The accumulated volume is reset by holding the down arrow/Stop button for three seconds. The display will countdown from 3 to 0.

Once the accumulated total is reset it is not possible to recover the value which was in the accumulated total.

### 6.9.7 Low Frequency Cut-Off

The low frequency cut-off parameter is used to adjust the minimum frequency required for the flow rate display. This setting is useful to avoid inconsistent flow rate display from unstable flow. The default value for the low frequency cut-off is 1Hz, and the parameter is adjustable from 0.1Hz up to 9.9Hz. It is not possible to enable a rate display for input frequencies below 0.1Hz.

This parameter also determines the amount of time at the end of a batch for the controller to determine that the flow has stopped. Reducing this parameter to values less than 1Hz will increase the wait time at the end of a batch before a new batch can be started.

### 6.9.8 Rate Calculation Pulses

The purpose of the 'Rate Calculation Pulses' parameter is to determine the number of input pulses which are used in calculation of the flow rate; the more pulses which are used the more accurately the Rate Display will represent the **average** flow rate of the system. The parameter is adjustable from 1 to 99 pulses per calculation.

For systems using pumps with a non-uniform rate of delivery (*piston pumps or similar*) it is important to have a high value for this parameter as it will produce a stable rate display which is representative of the average flow through the pipe.

For systems with a steady and uniform flow through the pipe, lower values can be used for this parameter in order to achieve a more responsive rate display. The default value is 4 which is generally a good compromise between stability of the flow rate display and responsiveness.

### 6.9.9 Flow Rate Filter

The Flow Rate Filter is used to smooth out fluctuating flow input signals to provide a stable flow rate display. This feature does not have any effect on the batch total calculations.

Most input signals are reasonably stable and need only the default setting, however for systems with large flow fluctuations the Filter setting may need to be increased. To remove all filtering from the flow rate calculation this parameter can be set to zero.

### 6.9.10 Backlight Override

The backlight is automatically enabled whenever external DC power is connected to the instrument; this feature may be overridden in this level of the program. The backlight override may be set to 'ON' (normal function), 'OFF' (always off).

## 6.10 Diagnostic Options

### 6.10.1 Serial Number

The serial number screen allows the user to see the serial number for their product. This number will also be shown on the physical label on the outside of the display enclosure. This number may be needed if you contact FLOMEC for technical assistance.

### 6.10.2 Input Frequency

The input frequency screen will display the current input frequency in Hertz on the LCD screen. This number is unaffected by any settings configured into the display by the user, so is therefore independent of any mistakes made in setting up the product. The input frequency display can be useful when troubleshooting flowmeter operation or determining if external noise is affecting measurement.

### 6.10.3 Voltage

The voltage display indicates to the user if the display is running on battery power, or if there is an externally connected DC voltage supply of sufficient voltage. This can be useful in situations where the batch is running but the pump or solenoid is not energized. The relay may not have sufficient power to operate the equipment.

### 6.10.4 Test Output

The Test Output function allows the user to manually switch the output transistor or mechanical relay. This is useful when commissioning or troubleshooting a solenoid valve or pump. By turning Test Output ON the user can test wiring and external equipment to ensure that it operates correctly, independent of any configuration settings in the batch controller or any faults with the flowmeter.

## 7. Troubleshooting

### 7.1 Troubleshooting Summary

<i>Symptom</i>	<i>Probable Cause</i>	<i>Corrective Action</i>
Inaccurate readings	<ol style="list-style-type: none"> <li>1. Incorrectly entered calibration data</li> <li>2. Electrical interference</li> <li>3. Mechanical or electrical fault with flow meter</li> <li>4. Flow meter requires recalibration</li> </ol>	<p>See 7.3.2</p> <p>Contact the manufacturer if a product fault is identified</p>
Batch total not counting or zero flow rate display. With flow in pipe	<ol style="list-style-type: none"> <li>1. Incorrect configuration – check sensor type</li> <li>2. Incorrect wiring</li> <li>3. Product fault</li> </ol>	<p>See 7.3.1</p> <p>Contact the manufacturer if product fault is identified</p>
Unclear characters on LCD	<ol style="list-style-type: none"> <li>1. Faulty LCD segment</li> </ol>	<p>Conduct LCD test – see section 5.1</p> <p>Contact the manufacturer if product fault is identified</p>
Solenoid valve not actuating	<ol style="list-style-type: none"> <li>1. No voltage or insufficient voltage at solenoid coil</li> <li>2. Incorrectly wired</li> <li>3. Incorrect solenoid valve type – must be normally closed (NC)</li> <li>4. Solenoid incorrectly specified, excess current draw has damaged the EB40</li> <li>5. Product fault</li> </ol>	<p>See 7.3.4</p> <p>Contact the manufacturer if product fault is identified</p>
Inconsistent or batch volumes	<ol style="list-style-type: none"> <li>1. Overrun Compensation feature is turned off</li> <li>2. Solenoid valve closing time is erratic</li> </ol>	<ol style="list-style-type: none"> <li>1. Turn on Overrun Compensation feature (see 5.3.7)</li> <li>2. Replace solenoid valve</li> </ol>
Controller suddenly stops after new batch is started	No signal detection feature is stopping the controller due to no signal from flow meter	See 7.3.1

## 7.2 Troubleshooting Steps

### 7.2.1 Total Not Counting or No Signal Error

If the total display on the EB40 is not counting it will be necessary to determine if the cause is a flow meter failure, failure of the EB40 itself, or incorrect setup of the EB40. If the EB40 starts and does not receive a flow meter signal after 10 seconds there will be a No Signal Error.

Following the below steps will allow the user to identify the likely fault.

1. Confirm the correct input type has been configured (**see section 6.7**)
2. Once the correct input type is set; use the Input Frequency diagnostics menu (**section 6.10.2**) to identify if an input signal is being detected by the EB40.
3. If an input signal is being detected, but the total display is not counting, please check your K-factor setting has not been programmed as zero (**read section 6.8**).
4. If an input signal is not being detected; disconnect the wires connecting your flow meter sensor to the EB40. With the input type set to REED, using a short piece of wire or a paperclip, momentarily connect the "Input1" terminal to the "GND" terminal to simulate the closing of a reed switch sensor. If the input frequency reading in the diagnostics menu shows a reading, the fault is with the flow meter or the wiring from the flow meter to the EB40.
5. If step 4 does not cause a reading on the Input Frequency display, there may be an electrical fault with the EB40, please contact FLOMEC technical support.
6. If an input signal is being detected by the EB40 but the **No Signal Error** is preventing the controller from operating, increase the number of seconds configured for the No Signal Detection feature (**read section 5.3.9**).

### 7.2.2 Zero Flow Rate

If the flow rate display on the EB40 is reading zero, but the total volume is counting there may be an issue with configuration settings. If the flow rate and total readings are both non-functional, please **see section 7.2.1** above. To troubleshoot please follow the below steps.

1. Ensure the units of measure are appropriate for the amount of flow in your pipe. If you have cubic metres set on your EB40 and are measuring flow in a ¼" pipe this may be an issue (**see section 6.3**)
2. Ensure the flowrate time-base is not set too large (i.e. /day) creating a value of flowrate too small to be displayed on the screen (**see section 6.4**)
3. Set the flowrate decimals to 3 to ensure sufficient resolution to pick up low flow rates (**see section 6.5**)
4. Set the low frequency cutoff setting to a lower value (**see section 6.9.7**)

5. Set the rate calculation pulses setting to the default value of 4 (*see section 6.9.8*)
6. Set the filter setting to the default value of 25 (*see section 6.9.9*)
7. If the issue persists the controller may be fault, please contact FLOMEC technical support.

### 7.2.3 Inaccurate Readings

If the EB40 display is showing inaccurate readings of flow rate or total volume the possible causes are; incorrect configuration settings in the EB40, electrical noise, or a faulty flow meter. Please follow the below steps to troubleshoot this issue.

1. Obtain the calibration certificate for your flow meter, if you no longer have the calibration certificate for your flow meter you will need to contact FLOMEC technical support or the FLOMEC distributor from whom you bought your flow meter. ***Please note: you will need to have the serial number for your flow meter, which is located on the flow meter itself – the serial number for your EB40 display is not the serial number you need.***
2. Once you have the calibration certificate for your flow meter please confirm the K-factor values have been correctly entered into the Calibration Data for the EB40 (*see section 6.8*). ***Please note that K-factor values must be entered in Litres even if you have chosen to display readings in another unit of measure.***
3. If calibration data is correct; while your flow meter is operating (there is flow) go to the Input Frequency diagnostics menu (*see section 7.1.2*). If the input frequency reading is erratic or unsteady, it is likely you have an issue with electrical noise interfering with the pulse signal from the flow meter. This issue will typically present as flow readings being too high on your EB40. Electrical noise issues can typically be fixed with shielded cables, properly grounded at the EB40 and isolated at the flow meter. Also, re-run cables away from solenoids and electric motors.
4. If all the above steps do not uncover a cause of the inaccurate readings, it is likely your flow meter is faulty, or in need of recalibration. Please refer to the instruction manual for your flow meter or refer to the flow meter manufacturer for technical support.

### 7.2.4 Valve not activating

If your EB40 is correctly displaying a flow rate and total but it is not activating the solenoid valve this may be due to a fault at either the EB40, the solenoid valve, or incorrect/broken wiring. To troubleshoot this fault please follow the below steps.

1. If your EB40 is not counting volume on the Total screen, and/or not displaying a flow rate reading, please first ***refer to sections 7.2.1 and 7.2.2***
2. Enable the “test output” function in the diagnostics menu (*see section 6.10.4*). If enabling this function causes the solenoid valve to open correctly, then there is

possibly a fault with the configuration of the EB40. Please read the configuration sections of this manual and check the values you have entered into the controller.

3. If the Test Output function does not correctly open the solenoid valve, then we must validate the compatibility of the solenoid valve with the power supply and check all wiring.
4. With the Test Output function still enabled measure the voltage at the terminals of the solenoid valve using a digital multi-meter, ***ensuring only qualified personnel take measurements on AC circuits***. Confirm correct polarity. If there is no voltage at the solenoid valve there is likely a power supply fault or a wiring fault. Also check that the voltage is compatible with the model of batch controller you have purchased.
5. If there is voltage at the solenoid valve but it is still not operating, check that the solenoid is a normally closed valve, and then confirm that the solenoid valve coil power is compatible with the rating of the batch controller model you have purchased (***see section 4.4***). If the power rating on the solenoid valve exceeds the rating on the EB40 there is a chance the EB40 has been damaged.

## 8. Configuration Menu Flowchart

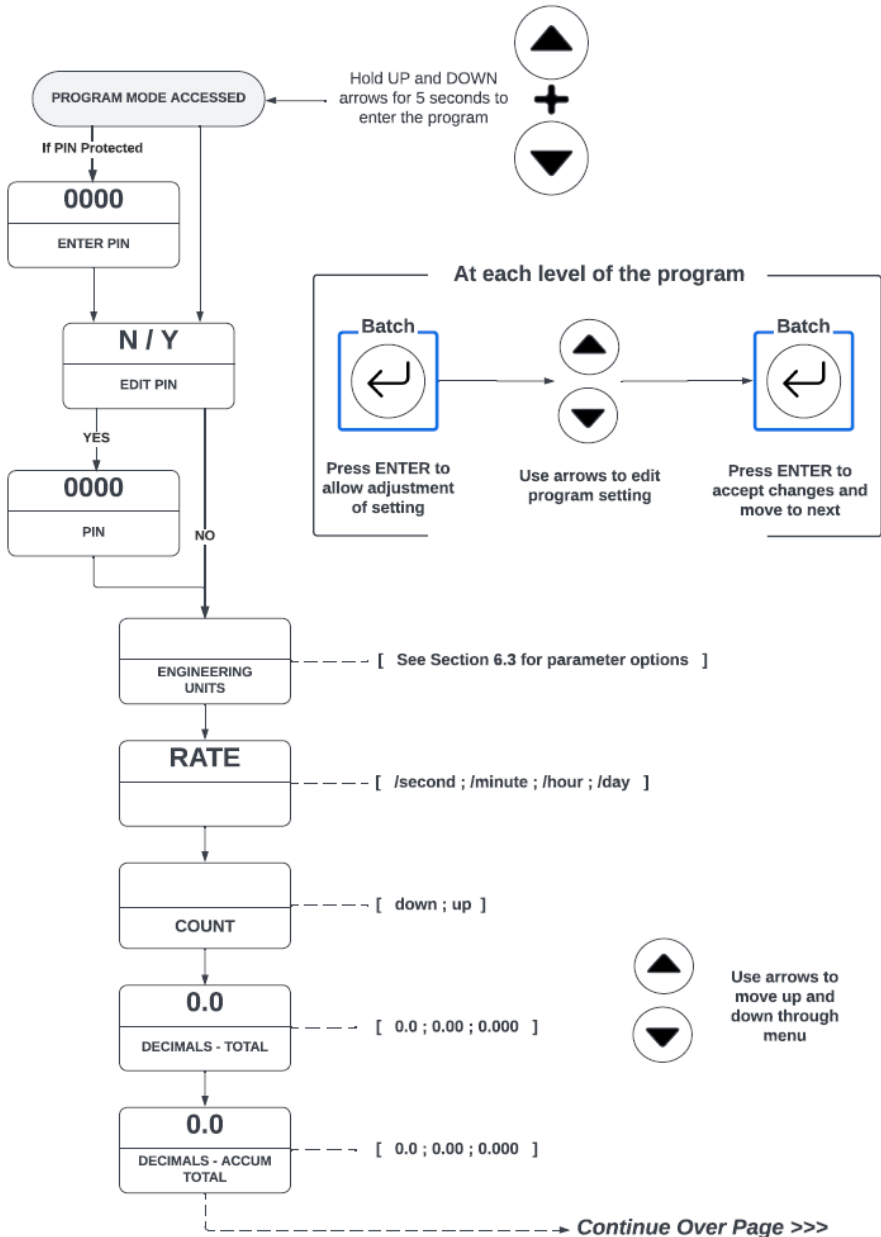

>>> From Previous Page

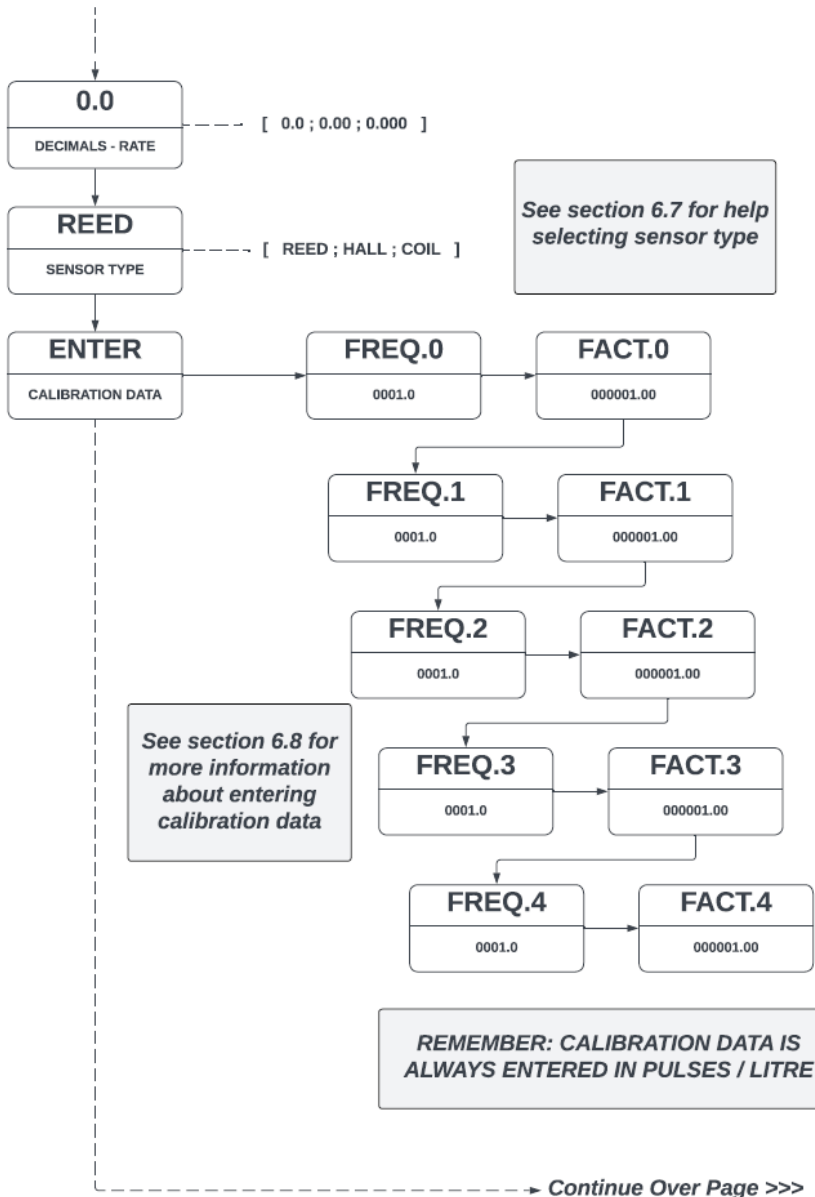

>>> From Previous Page

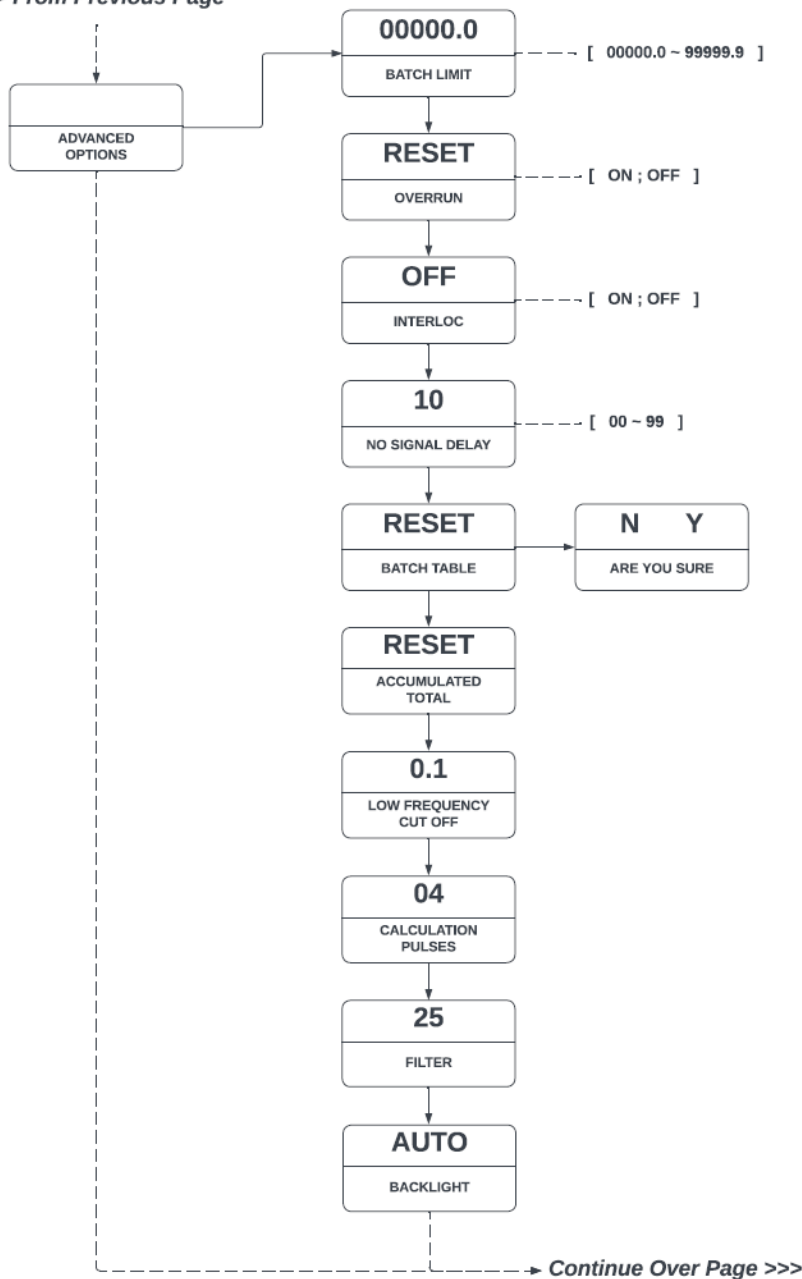

>>> From Previous Page

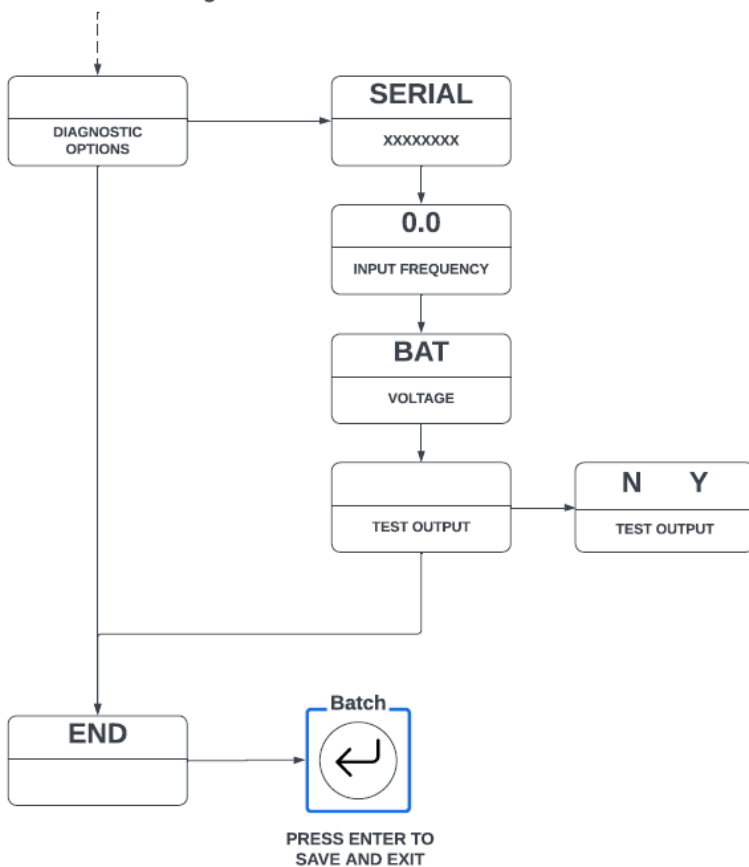

## 9. Spare Parts

***Spare parts for your instrument are available from the local dealer or national distributor from whom you purchased the instrument; see spare parts list below to determine which part numbers you require.***

<b>Description:</b>	<b>Includes:</b>	<b>Part No:</b>
Front Housing Kit (Nylon)	Front housing (glass reinforced nylon), screen cover, FLOMEC decal, screws, and gasket	1502072
Front Housing Kit (Aluminium)	Front housing (aluminium), screen cover, FLOMEC decal, screws, and gasket	1502073
Meter Mount Rear Housing Kit (GRN)	Rear housing for meter mounted instrument (glass reinforced nylon); Includes the required fasteners and seals for meter mounting	1502069
Meter Mount Rear Housing Kit (Aluminium)	Rear housing for meter mounted instrument (aluminium); Includes the required fasteners and seals for meter mounting	1502034
Field Mount Rear Housing Kit (GRN)	Rear housing for field mounted instrument (glass reinforced nylon)	1502068
Field Mount Rear Housing Kit (Aluminium)	Rear housing for field mounted instrument (aluminium)	1502035
Screen protector kit	Polycarbonate screen cover, and screws	1506018
Housing Gasket	Enclosure seal (suits both nylon and aluminium enclosures)	1304024
Meter Mount Seal	BS039 Buna-N (Nitrile) O-Ring	BS039B
Decal (facia)	Self-adhesive decal (facia) with FLOMEC logo	1315187
Replacement Battery	3.6V AA Lithium Thionyl Chloride Battery	1312125
<i>Alternative Replacement Battery for Safe Area Units Only</i>		Tekcell SB-AA11 Tadiran TL5903/S
Wall Mount Kit	2x wall mount brackets, 4 mounting screws	1522001
Pipe Mount Kit	Wall mount kit plus pipe clamps	1522002

## 10. EU Declaration of Conformity

**Product Models:** FLOMEC EB40 Series Batch Controllers

**Manufacturer:** Trimec Industries Pty. Ltd.  
12/7-11 Parraweena Road  
Caringbah, NSW 2229  
Australia

This declaration of conformity is issued under the sole responsibility of the manufacturer.

Conformity is based on the application of the harmonised standards listed below, and where necessary through certification by a European Union Notified Body.

**2014/30/EU EMC Directive**

**Harmonised standards:** EN61326-1:2021

**2011/65/EU RoHS Directive**

**Harmonised standards:** EN50581:2012  
EN IEC 63000:2018

Signed for and on behalf of the manufacturer:



Matthew Wyres,  
General Manager  
Trimec Industries Pty. Ltd.

Sydney, Australia  
27<sup>th</sup> February 2026



## **FLOMEC® TWO-YEAR LIMITED WARRANTY (USA)**

Great Plains Industries, Inc. 5252 E. 36th Street North, Wichita, KS USA 67220-3205, hereby provides a limited warranty against defects in material and workmanship on all products manufactured by Great Plains Industries, Inc. This product includes a two (2) year warranty. Manufacturer's sole obligation under the foregoing warranties will be limited to either, at Manufacturer's option, replacing or repairing defective Goods (subject to limitations hereinafter provided) or refunding the purchase price for such Goods theretofore paid by the Buyer, and Buyer's exclusive remedy for breach of any such warranties will be enforcement of such obligations of Manufacturer. The warranty shall extend to the purchaser of this product and to any person to whom such product is transferred during the warranty period.

The warranty period shall begin on the date of purchase from the Manufacturer or from the Manufacturer's approved distributor/representative, with original proof of purchase (sales receipt/invoice). Or, if such proof is unavailable on the date of manufacture. This warranty shall not apply if:

- A. the product has been altered or modified outside the warrantor's duly appointed representative;
- B. the product has been subjected to neglect, misuse, abuse or damage or has been installed or operated other than in accordance with the manufacturer's operating instructions.

To make a claim against this warranty, or for technical assistance or repair, contact your FLOMEC distributor or contact FLOMEC at:

**Great Plains Industries, Inc.**

5252 East 36th St. North Wichita, KS 67220-3205 USA

888-996-3837

[www.flomecmeters.com](http://www.flomecmeters.com)

The company will step you through a product troubleshooting process to determine appropriate corrective actions.

GREAT PLAINS INDUSTRIES, INC., EXCLUDES LIABILITY UNDER THIS WARRANTY FOR DIRECT, INDIRECT, INCIDENTAL AND CONSEQUENTIAL DAMAGES INCURRED IN THE USE OR LOSS OF USE OF THE PRODUCT WARRANTED HEREUNDER.

The company herewith expressly disclaims any warranty of merchantability or fitness for any particular purpose other than for which it was designed.

This warranty gives you specific rights and you may also have other rights which vary from U.S. state to U.S. state.

NOTE: In compliance with MAGNUSON MOSS CONSUMER WARRANTY ACT – Part 702 (governs the resale availability of the warranty terms).



## **FLOMEC® TWO-YEAR LIMITED WARRANTY (AUSTRALIA)**

Great Plains Industries Australia hereby provides a limited warranty against defects in material and workmanship on all products manufactured by Great Plains Industries Australia (Trimec Industries Pty. Ltd.) and Great Plains Industries, Inc. This product includes a two (2) year warranty. Manufacturer's sole obligation under the foregoing warranties will be limited to either, at Manufacturer's option, replacing or repairing defective Goods (subject to limitations hereinafter provided) or refunding the purchase price for such Goods theretofore paid by the Buyer, and Buyer's exclusive remedy for breach of any such warranties will be enforcement of such obligations of Manufacturer. The warranty shall extend to the purchaser of this product and to any person to whom such product is transferred during the warranty period.

The warranty period shall begin on the date of purchase from the Manufacturer or from the Manufacturer's approved distributor/representative, with original proof of purchase (sales receipt/invoice). Or, if such proof is unavailable on the date of manufacture. This warranty shall not apply if:

- A. the product has been altered or modified outside the warrantor's duly appointed representative;
- B. the product has been subjected to neglect, misuse, abuse or damage or has been installed or operated other than in accordance with the manufacturer's operating instructions.

To make a claim against this warranty, or for technical assistance or repair, contact your local FLOMEC distributor or contact Great Plains Industries Australia (Trimec Industries Pty. Ltd.)

### **GPI Australia (Trimec Industries Pty. Ltd.)**

12/7-11 Parraweena Road Caringbah NSW 2229 Australia

+61 02 9540 4433

[www.flomec.com.au](http://www.flomec.com.au)

The company will step you through a product troubleshooting process to determine appropriate corrective actions.

GREAT PLAINS INDUSTRIES AUSTRALIA, EXCLUDES LIABILITY UNDER THIS WARRANTY FOR DIRECT, INDIRECT, INCIDENTAL AND CONSEQUENTIAL DAMAGES INCURRED IN THE USE OR LOSS OF USE OF THE PRODUCT WARRANTED HEREUNDER.

The company herewith expressly disclaims any warranty of merchantability or fitness for any particular purpose other than for which it was designed.

***Trimec Industries Pty. Ltd. T/A Great Plains Industries Australia also provides automatic guarantees of all goods according to Australian Consumer Law.***